

Part No 66000766

## Pro-Series /Fish Rope Guard and Control Arm Upgrade Kit

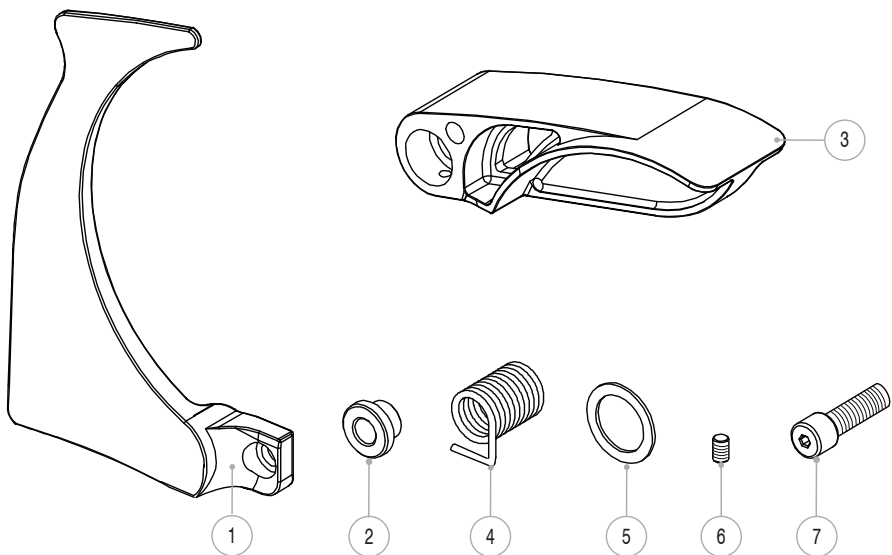

### Kit contains the following:

1. Rope guard
2. Guard spacer
3. Control arm
4. Torsion spring
5. Pivot pin washer
6. Grub screw
7. Cap screw M6 x 20mm

### Tools required

- 2 mm (5/64") Allen key
- 4 mm (5/32") Allen key
- 6 mm (15/64") Allen key
- Pro-Series clutch spanner
- Screw fixing compound

**Note:** Illustration based on the Pro-Series



Remove gypsy, cone and drive pins using clutch nut spanner and Allen key for the stripper screws.

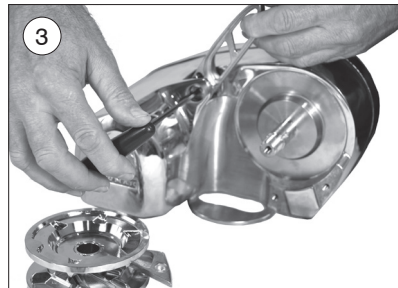
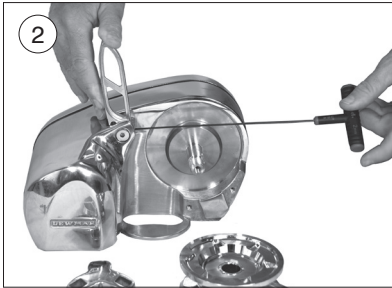
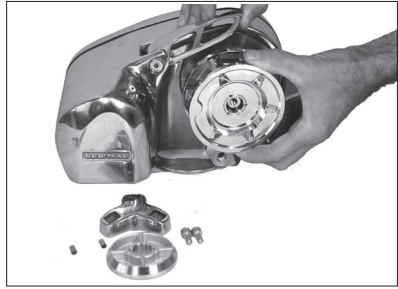

Raise the control arm and remove the grub screw located at the base of the arm using the 2mm (5/64") Allen key. This is fixed with loctite, gentle heat will aid removal.

Using the 4mm(5/32") Allen key, push and turn locating pin clockwise, then withdraw the pin outwards. The arm and washer can then be removed.

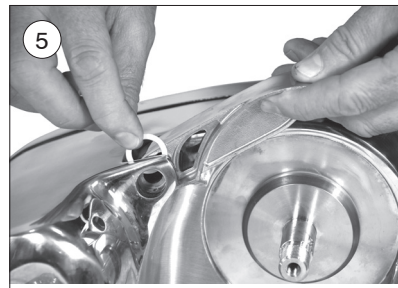

Fit new torsion spring

Fit new arm and washer.

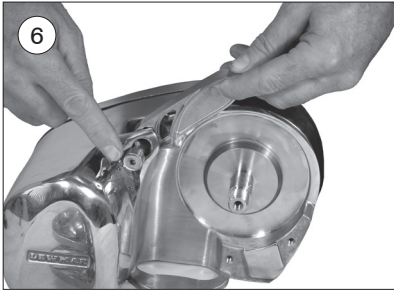

Replace pin by using the 4 mm (5/32") Allen key, push and rotate pin anticlockwise. The pin should then spring out and locate.

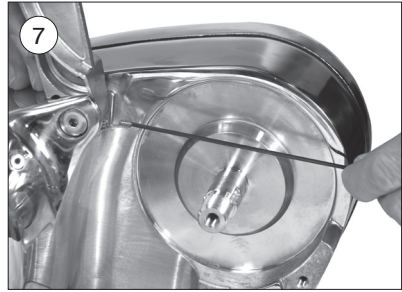

Replace grub screw using fastening compound.

8 Replace gypsy, drive pins and clutch nut, tighten using clutch nut spanner.



Fit spacer as shown.

**NOTE : Spacer not required on Pro-Fish models**

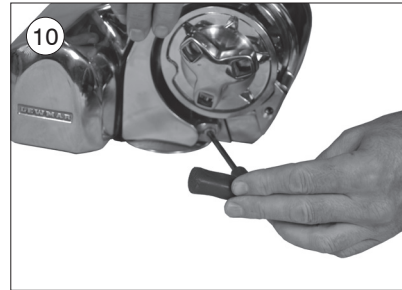

Place rope guard in place and secure using M6 x 20 screw and fastening compound.



The new rope guard and control arm kit is fitted

## **UK & International Distribution**

Lewmar / Navtec  
Southmoor Lane  
Havant  
Hampshire  
PO9 1JJ  
England

**Tel:** +44 (0)23 9247 1841

**Fax:** +44 (0)23 9248 5720

**Email:** [info@lewmar.com](mailto:info@lewmar.com)

## **USA**

Lewmar / Navtec  
351 New Whitfield Street  
Guilford, CT  
06437  
USA

**Tel:** +1 203 458 6200

**Fax:** +1 203 453 5669

**Email:** [info@lewmarusa.com](mailto:info@lewmarusa.com)

**[www.lewmar.com](http://www.lewmar.com)**

Manual Part No : B10413 Issue 3